

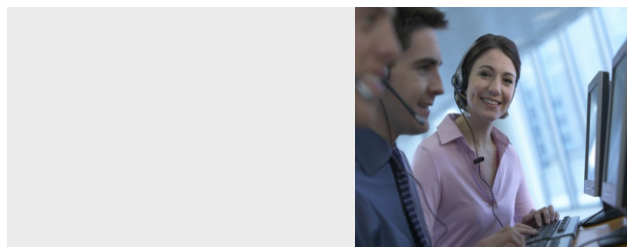

Pancode VoIP Pantel VoIP

Access Control Door Phones



Installation and Programming Manual

Version 2 Release 7

June 2008

NOTICE

This publication refers to the PANCODE IP and Pantel IP Door Access Control devices, Version 2.

Additional copies of this manual may be obtained from ITS Ltd. Reproduction of this manual or parts thereof without written permission from ITS is strictly prohibited.

ITS Ltd. reserves the right to modify the hardware and software described herein without prior notice. However, changes made to the hardware or software described do not necessarily render this publication invalid.

WARRANTY

In the event that the product proves to be defective in workmanship or materials within a period of one year from date of shipment, ITS Ltd. shall repair or replace the same at its discretion. Transportation will be the responsibility of the dealer/distributor.

Under no circumstances shall ITS Ltd. be liable for consequential or special damages, loss of revenue or user/dealer expenses arising out of or in connection with the use or performance of the product, whether base on contract, tort or any other legal agreement.

The following shall void the above warranty: malfunctions resulting from fire, accident, neglect, abuse or acts of God; use of improper electrical power; or repair of, tampering with or alteration of the product by anyone other than ITS authorized.

Table of Contents

1.	Introduction	2
1.1	Pancode VoIP/Pantel VoIP Kit Contents.....	3
2.	Physical Description.....	4
2.1	Pancode VoIP Front Panel	4
2.2	Pantel VoIP Front Panel.....	5
3.	Installation	6
4.	Pancode VoIP/Pantel VoIP Schematic Setup	7
5.	Installing the Pantel VoIP/Pancode VoIP	8
5.1	Installing the Video Camera (Optional)	11
6.	Adjacent Access Control Device	12
7.	Programming	14
7.1	Searching for a Device in LAN.....	15
7.2	Scanning for a Device in the Network.....	17
7.3	Application Interface	18
7.4	System Parameters	19
7.5	VoIP Dialing settings.....	22
8.	Firmware/Software Upgrade.....	26
8.1	Firmware/Software Upgrade Procedure	26
9.	Technical Specification	28
9.1	Analog Video Camera Technical Specification	29

1. Introduction

This guide provides installation and programming instructions for the following products:

- Pancode VoIP outdoor piezo keypad unit
- Pantel VoIP outdoor piezo keypad unit

The Pancode VoIP and Pantel VoIP are smart wall-mounted access control door phones connected to a local Voice Over IP (VoIP) network of a VoIP PBX, allowing door entry control. They are available for outdoor installation in an aluminum unit with a piezo keypad.

The Pancode VoIP and Pantel VoIP have the following features:

Feature	Pancode VoIP	Pantel VoIP
Integration with local LAN and VoIP networks	✓	✓
Authorized registration with existing VoIP switching system (Proxy)	✓	✓
Two different operation modes: Standard – for direct dialing to any destination number Speed-dial – for one-touch dialing to internal or external subscribers	✓	✗
Automatic busy & disconnect detection	✓	✓
Door opening from any extension	✓	✓
Door opening from Bypass Switch button	✓	✓
Programmable day and night destinations	✓	✓
High quality speakerphone with separate volume control	✓	✓
Entry access code (supports up to ten codes)	✓	✗
Works in conjunction with card readers and security devices	✓	✓
Programming via Ethernet interface using a web-based GUI application	✓	✓
Acoustic echo canceller	✓	✓
Automatic gain control (AGC)	✓	✓
SRTP (encryption and authentication)	✓	✓
Support for analog video (optional)	✓	✓
Internal network switch	✓	✓
Smart looking durable design	✓	✓
Software upgrade	✓	✓

1.1 Pancode VoIP/Pantel VoIP Kit Contents

The contents of the Pancode VoIP/Pantel VoIP are as follows:

- Pancode VoIP or Pantel VoIP unit
- External 12V AC power supply
- Ethernet cable
- Installation CD

NOTE

Device is available with internal B&W or color video camera.
Video camera must be ordered separately.

2. Physical Description

The Pancode VoIP and Pantel VoIP are attached to the wall using a bracket and screws. These units are hardwired and powered by an external 12V AC transformer, included in the package. The Pancode VoIP and Pantel VoIP dimensions are:

- Height: – 19.4 cm
- Width: – 10.2

2.1 Pancode VoIP Front Panel

The front panel of the Pancode VoIP unit contains a built-in speaker, a microphone, touch-keypad and internal video camera hole (optional) (Figure 2-1).



Figure 2-1. Pancode VoIP Front Panel

2.2 Pantel VoIP Front Panel

The front panel of the Pantel VoIP unit contains a built-in speaker, a microphone, call button and internal video camera hole (optional) (Figure 2-2).

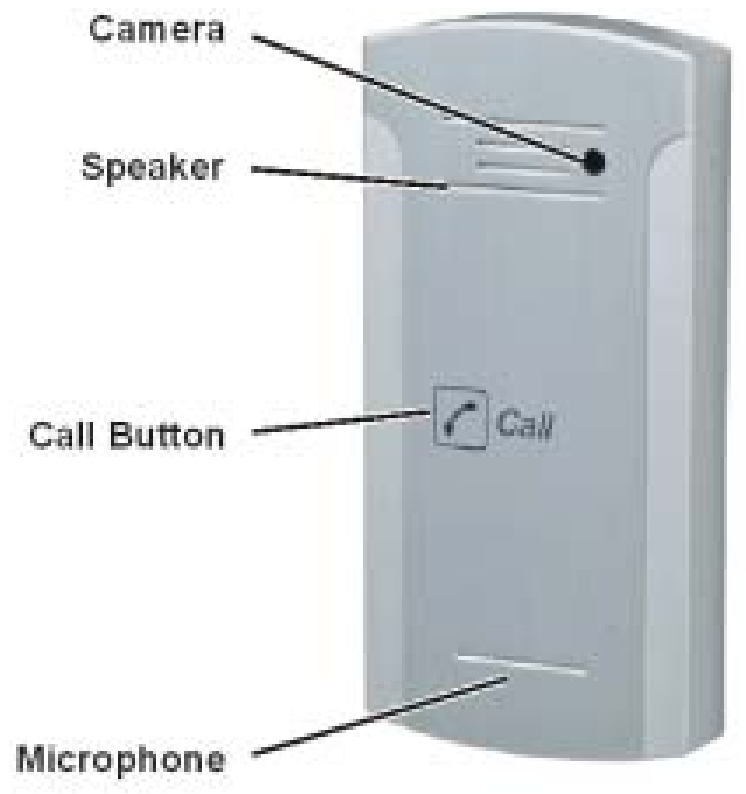

Figure 2-2. Pantel VoIP Front Panel

3. Installation

The Pantel VoIP/Pancode VoIP is mounted on the provided installation bracket. This mounting bracket should be installed as shown in Figure 3-1.

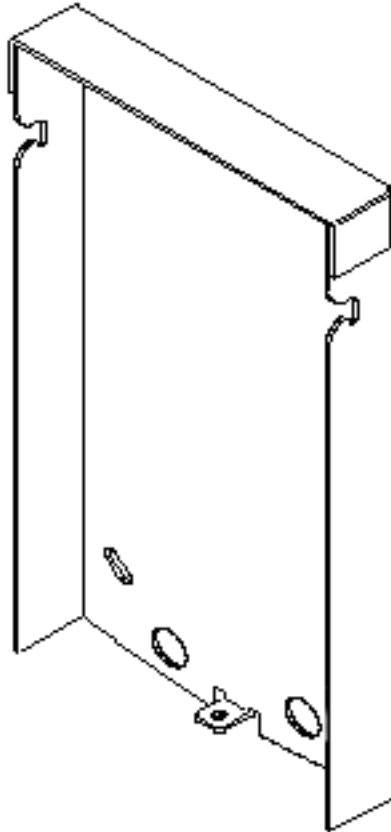

Figure 3-1. Installation Bracket

To install the wall bracket:

- a. Measure and mark the location on the wall where the holes will be drilled for the mounting bracket.
- b. Drill the holes and insert the wall anchors into the holes.
- c. Attach the mounting bracket using the provided wall screws.

4. Pancode VoIP/Pantel VoIP Schematic Setup

The Pancode VoIP/Pantel VoIP unit is connected to the VoIP PBX as a SIP extension or via any IP router (Network HUB, Switch etc). The unit powers the door lock, provided it is powered by an external supply and not PoE. The unit includes the internal 2 port's network switch which allows additional network equipment connecting (PC, External video IP server etc...) directly via VoIP Pancode / Pantel. Figure 4-1 details the unit schematic setup.

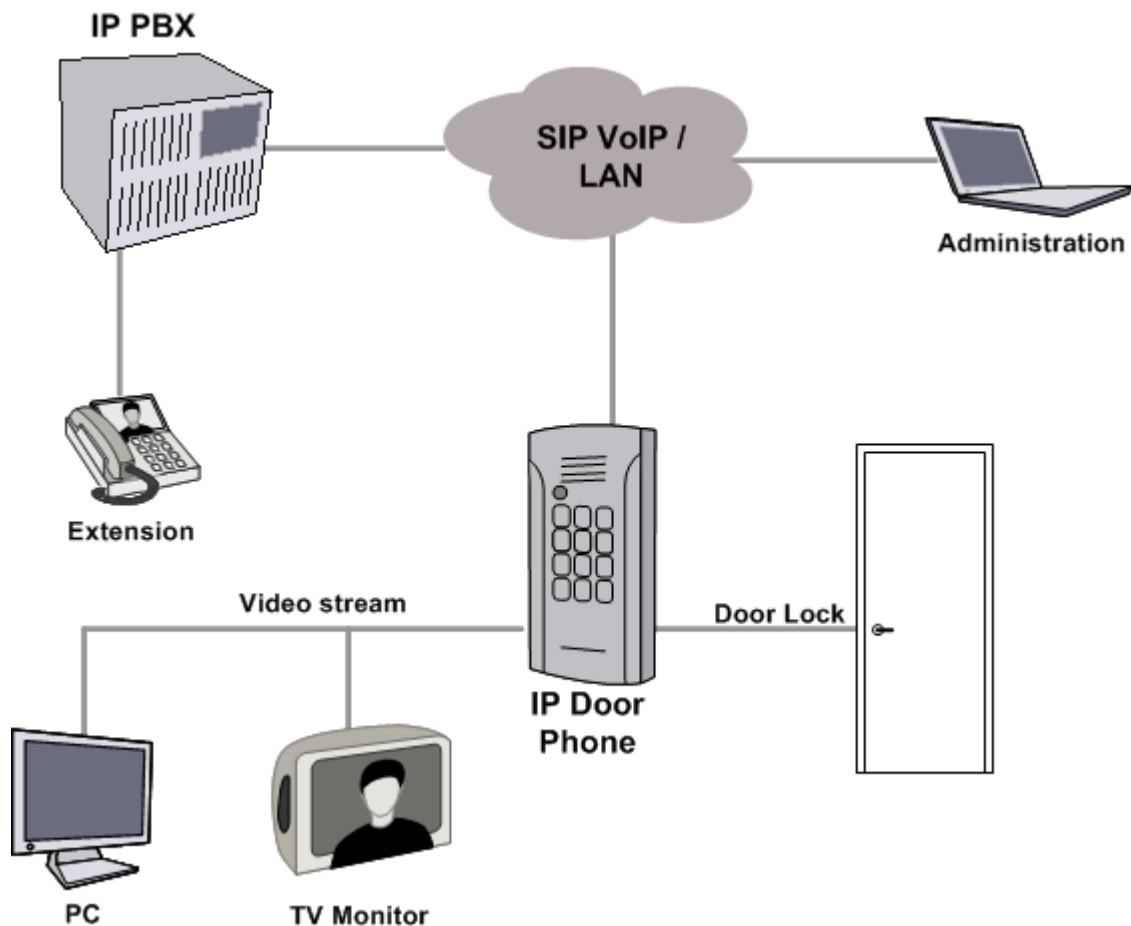

Figure 4-1. Schematic Setup

5. Installing the Pantel VoIP/Pancode VoIP

The Pantel VoIP/Pancode VoIP can be installed as an individual access control or used with adjacent access-control devices, such as card reading devices (see Section 6).

The provided 12V AC external power supply should not be located further than 10m (30ft) from the unit.

These units also support Power Over Ethernet (PoE), meaning that they could operate when connected to Ethernet without mains. However, **the current provided by the PoE supply is insufficient for opening a door.** If your system is equipped with door lock relay, make sure to use the external supply.

Figure 5-1 shows the terminal locations on the wire connector provided with the unit. This connector is attached at the base of the internal component. All wiring to the unit is attached to the wire connector.

NOTE

When holding the unit as displayed in Figure 5-2, the first pin from the right is the first ~12V pin.

The Pantel VoIP/Pancode VoIP supports a bypass switch installation. This allows opening the door with a hardwired switch. A bypass switch should be connected to the SW and /SW terminals.

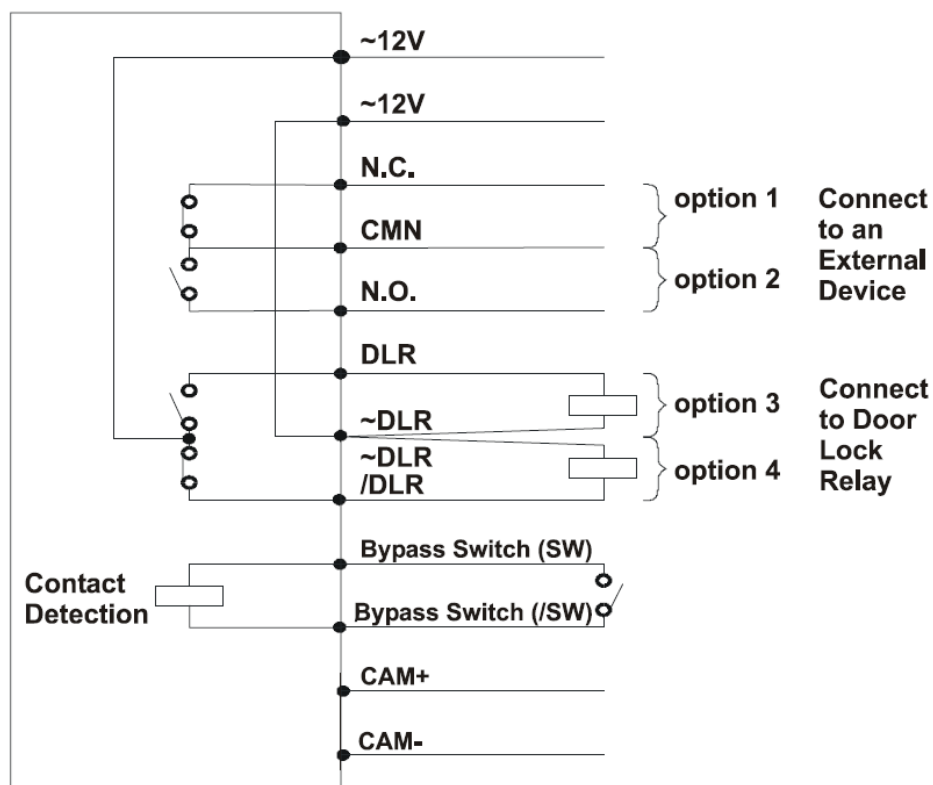

Figure 5-1. Connectors Scheme

NOTE

For the installation of the powered-unlocked-state, use DLR and ~DLR. For the installation of the powered-locked-state, use /DLR and ~DLR (**this is recommended for safety purposes**).

The wiring connector can be a screw or insert connector type. In case when connector is wired type in order to attach a wire, you must insert the stripped end of the wire into the proper terminal and tighten the terminal screw. This will crimp the wire connection.

To Install the Pantel/Pancode VoIP:

- a. Remove the cover from the Pantel VoIP/Pancode VoIP unit and disconnect the wire connector, found at the base of the internal component.
- b. Connect the two 12V lead wires from the 12V AC power adapter, one to each of the **"~12V"** terminals (Figure 5-1).
- c. Connect the Ethernet cable to the RJ-45 "PORT 0" straight LAN socket (Figure 5-2 and Figure 5-3) by means to program the unit using the Web-based GUI (see Section 7).
- d. Connect the door-lock relay wires to the **"DLR"** and **"~DLR"** terminals
- Or -
If the door-lock relay is a powered-locked-state type lock, connect the door-lock relay wires to the **"/DLR"** and **"~DLR"** terminals.
- e. If a push button switch is used, connect the push button wires to the **"SW"** and the **"/SW"** terminals.
- f. Plug the wire connector to the base of the unit's inner component.
- g. Switch on the power to the 12V adapter.

NOTE

1. After power-up or reset, the Pancode/Pantel device starts an initialization process, which can take up to 20 seconds. The initialization completion is indicated by short busy signal.
 2. Device can be detected in the LAN by using the MAC address shown on the label and QUERY utility from the installation CD. In cases where the MAC address is unknown, device can be detected by using the SCAN utility from the installation CD (see Paragraph 7.1 and 7.2).
 3. When SIP parameters are updated, an automatic power reset is required. The programming is not done in real time. Make sure to apply the settings to the unit.
-

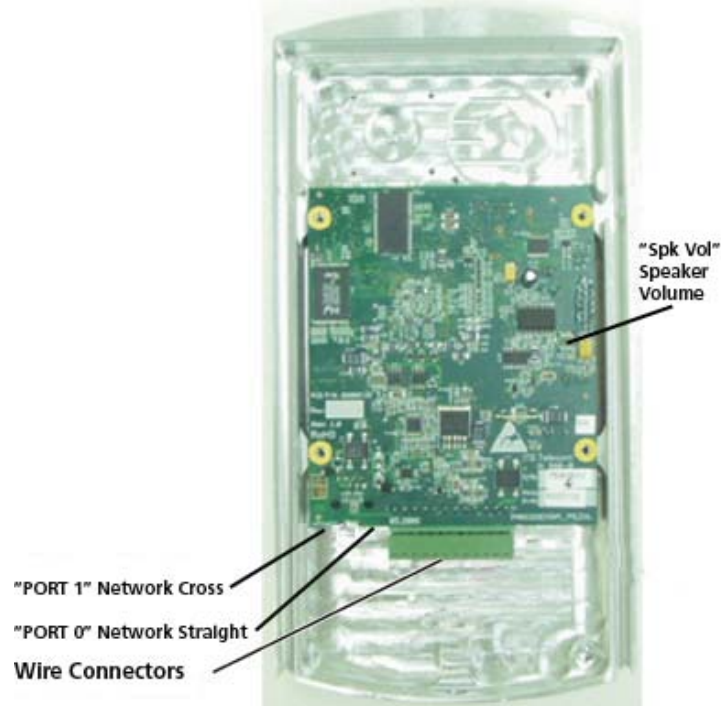

Figure 5-2. Unit Connectors

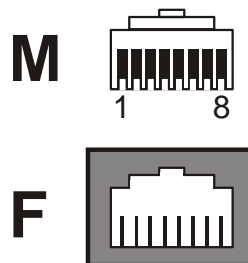

Figure 5-3. RJ-45 Connector

NOTE

1. "PORT 0" RJ-45 Network connector required direct (straight) cable connection with the LAN. "PORT 1" RJ-45 Network connector required the Cross-linked cable connection.
2. "SPK. VOL" potentiometer allows the internal Speaker default volume adjustment.

5.1 Installing the Video Camera (Optional)

The Pantel VoIP/Pancode VoIP unit can be installed with an analog video camera. The video camera 12VDC power is supplied via the 11 and 12 pins located on the Main Connector (see Figure 5-4).

The video camera is constantly transmitting images using an analog video stream. The video stream can be routed directly to a TV Monitor or connected to a PC using a USB adaptor.

NOTE

The USB adaptor must be ordered separately.

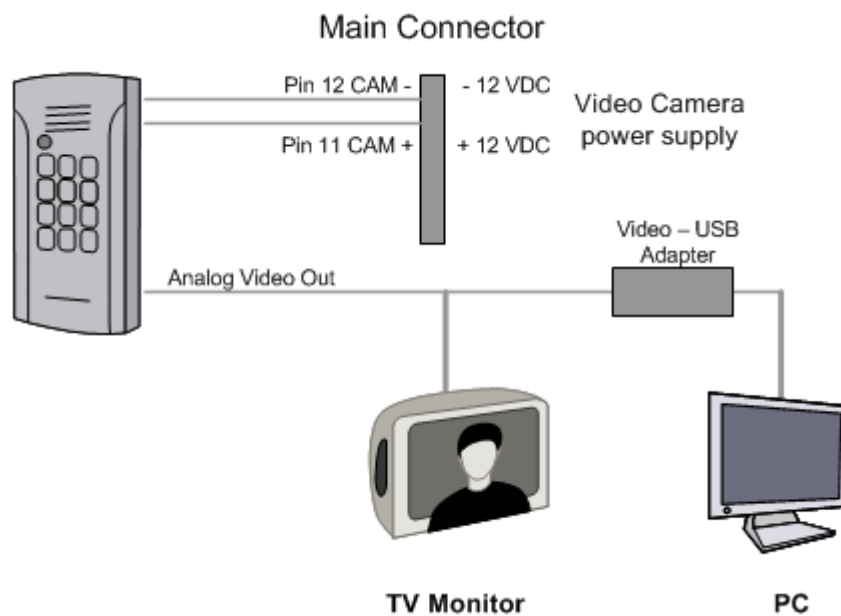

Figure 5-4. Video Camera Connection Scheme

6. Adjacent Access Control Device

This section describes adding an access-control device to an existing Pantel VoIP/Pancode VoIP, and adding a Pantel VoIP/Pancode VoIP to an existing access-control device. The key difference between these two installations is which access-control device controls the door lock relay.

To add an access control device to a Pantel VoIP/Pancode VoIP:

When activated, the access-control triggers the Pantel/Pancode "SW" terminal, which activates the door-lock relay and opens the door.

For this type of installation, the access-control device "N.O." output wires are connected to the Pantel VoIP/Pancode VoIP Switch terminals (see Figure 6-1).

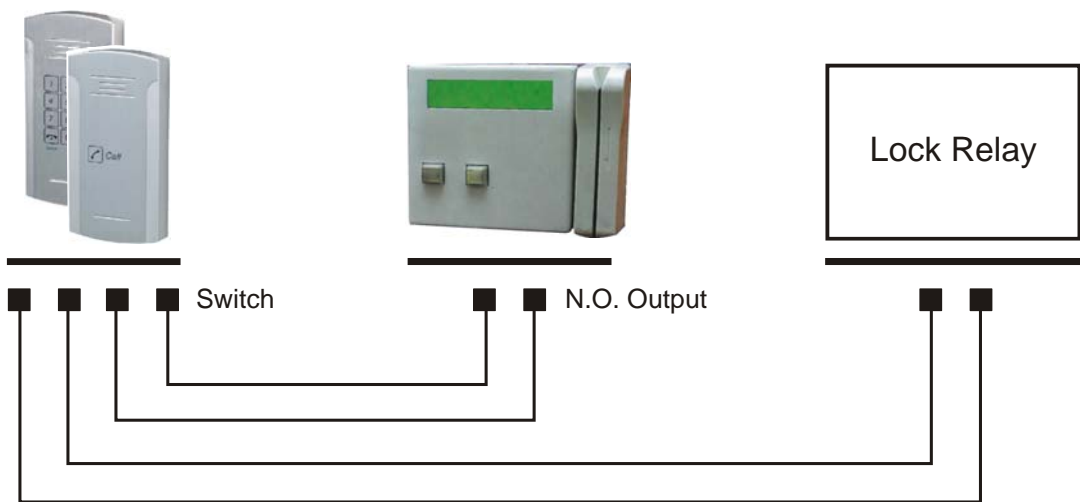

Figure 6-1. Controlling Lock Relay

To add a Pantel VoIP/Pancode VoIP to an access control device:

The access control device opens the door when the Pantel/Pancode triggers the access-control device.

For this installation, the access-control device “**Bypass Switch**” (SW) wires are connected to the “**N.O.**” and “**CMN**” terminals of the Pantel/Pancode. The door-lock relay wires are connected to the access-control device (see Figure 6-2).

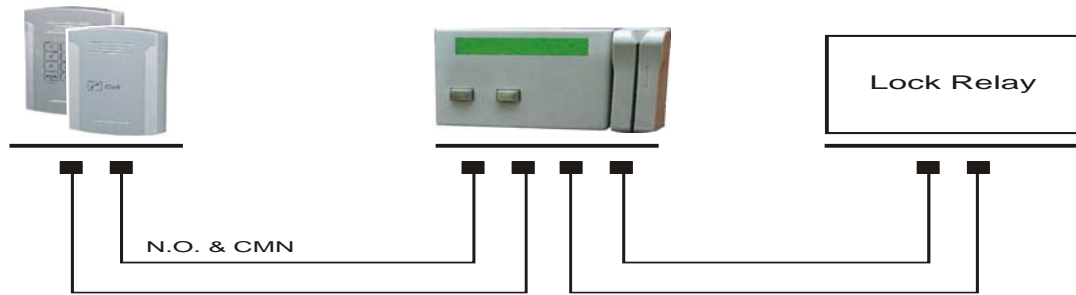

Figure 6-2. Access Control – Controlling Lock Relay

Connection schematics:

The Pantel VoIP and Pancode VoIP offer multiple wiring options:

- **Option 1:** For use with an external device, which requires the unit to be set up as “Normally Closed”.
- **Option 2:** For use with an external device, which requires the unit to be set up as “Normally Open”.
- **Option 3:** For use with the powered-unlocked-state lock relay (most common).
- **Option 4:** For use with the powered-locked-state lock relay (**recommended for safety purposes**).

7. Programming

The Pancode VoIP/Pantel VoIP units are programmed through web-based GUI interface. This process can be implemented after the unit has been installed on the wall, since it requires the connection of an Ethernet cable to the local network. Optionally possible to establish connection between PC and Pancode by using the cross-linked Ethernet cable.

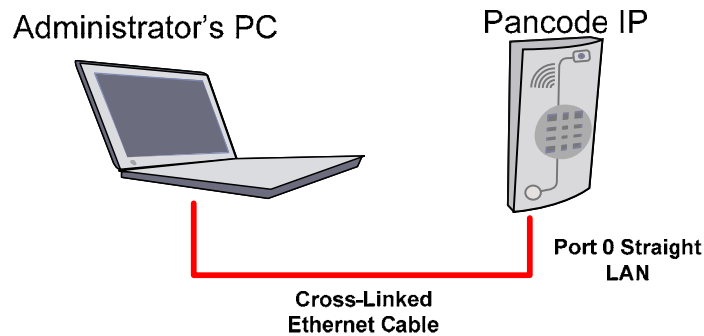

Figure 7-1 Cross-linked Ethernet cable connection

Following table shows the Cross-linked cable pin-out connections.

PC side pins	Pancode IP pins
1	3
2	6
3	1
6	2

The programming with using the cross-linked cable required specific PC Network settings. PC has to be configured to operate in the same Network IP address segment with the Pancode IP unit. The default Pancode IP network address is **192.168.1. 229**. Administrator's PC must be able to support the network connection with the default Pancode IP address. For these purposes:

- Go to the OS Windows Network settings. For the Windows XP: Control Panel → Network connections → Relevant Local Area Connection → Properties → Select Internet Protocol (TCP/IP) → Press Properties button
- Select the "Use the following IP address " option
- Enter Network parameters as shown as example on the following figure.

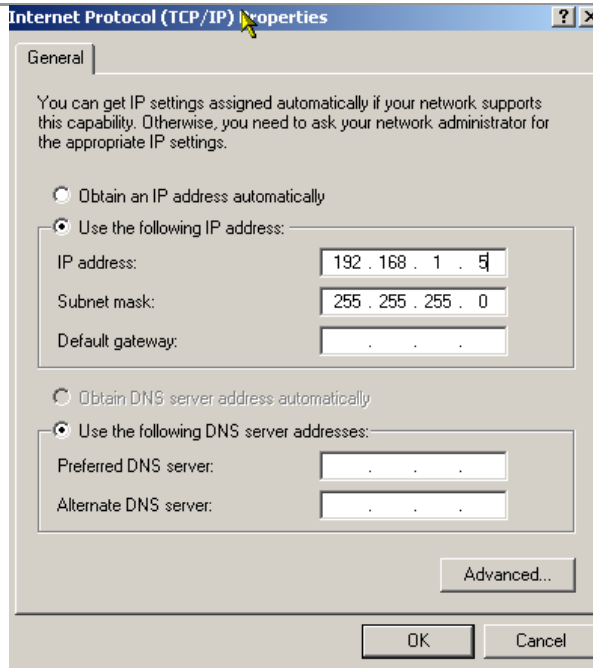

Figure 7-2 PC Network parameters for the Gross-linked cable connection

- Press OK → exit from the PC Network settings and enter to the Pancode IP first web-programming

NOTE

Don't forget to return the Administrator's PC network settings to the local network required after the first Pancode IP programming session will be finished.

The programming application is launched from the web browser (preferably MS Internet Explorer version 5.5 or higher). It is possible to run the application by typing the following address in the address bar: <http://XXX.XXX.XXX.XXX/pancode> (Figure 7-3).

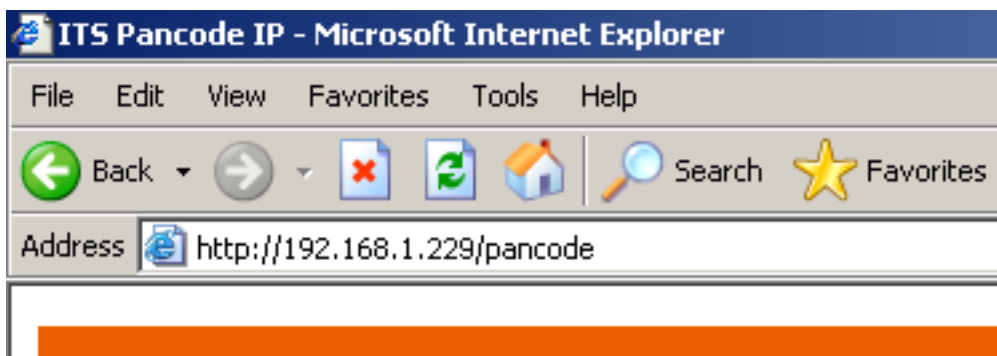

Figure 7-3. ITS Pancode IP Web Page

7.1 Searching for a Device in LAN

When the IP address is unknown, it is possible to find the unit in the LAN using the QUERY utility from the installation CD.

NOTE

Unit location through a query is possible only when the unit MAC address is known. It appears on the label attached to the rear panel of the device.

Use Lower Case only for letters which presents in the MAC address

To find the unit in the network:

- Insert the installation CD and copy the **query.exe** file from the **Software** directory to the local hard drive.
- Start MS Windows DOS prompt application.
- Access the directory, in which the **query.exe** application exists.
- Enter the following command: `query XX:XX:XX:XX:XX + <Enter>`, where `XX:XX:XX:XX:XX` is the MAC address. A search for the device takes place, at the end of which the unit IP address appears (Figure 7-4).

```
C:\\VOIP\NEWFIRMWARE>query 00:01:02:03:04:12
Target IP = 192.168.1.38
C:\\VOIP\NEWFIRMWARE>
```

Figure 7-4. Searching for Device Using Query

7.2 Scanning for a Device in the Network

When the unit MAC address is unknown, it is possible to find an existing device in the network using the SCAN utility from the installation CD.

NOTE

SCAN utility required for any OS Windows based network capturing utility installation. For example: The Wireshark utility which can be downloaded from the link <http://www.wireshark.org/download.html>

To find a device in the network:

- Insert the installation CD and copy the **scan.exe** file from the **Software** directory to the local hard drive.
- Disconnect the Pancode VoIP/Pantel VoIP from the external power supply.
- Start MS Windows DOS prompt application.
- Access the directory, in which the **scan.exe** application exists.
- Enter the following command: scan + <Enter>. A scan takes place, at the end of which the installed PC Ethernet adaptor appears (Figure 7-).

```
PancodeIP scan utility (ver=1.01)
CTRL+C for Exit

This Host includes the following interface :
1) \Device\NPF_{GenericDialupAdapter} (Generic dialup adapter)
2) \Device\NPF_{3D1B5BC2-16F5-4BE0-B1F8-385D00FB6260} (Broadcom NetXtreme Gigabit Ethernet Driver)
Enter the interface number (1-2):1

listening on Generic dialup adapter...
_
```

Figure 7-3. Searching for Device in the Network

- Select the required Ethernet adaptor.
- Press **Enter**.
- Switch On the power!** A scan for the device takes place, at the end of which the detected Pancode/Pantel device IP information, including MAC address and network settings, appears (Figure 7-).

```
listening on NDIS 5.0 driver
...
Receive Pancode Broadcast: MAC=00:01:02:03:04:12 IP=192.168.1.67 MASK=255.255.255.0 GW=192.168.1.2
Receive Pancode Broadcast: MAC=00:01:02:03:04:12 IP=192.168.1.67 MASK=255.255.255.0 GW=192.168.1.2
Receive Pancode Broadcast: MAC=00:01:02:03:04:12 IP=192.168.1.67 MASK=255.255.255.0 GW=192.168.1.2
Receive Pancode Broadcast: MAC=00:01:02:03:04:12 IP=192.168.1.67 MASK=255.255.255.0 GW=192.168.1.2_
```

Figure 7-4. Search Results for Device in the Network

7.3 Application Interface

When running the application, the main screen opens, comprising the navigation menu, parameters fields and functional buttons (Figure 7-5).

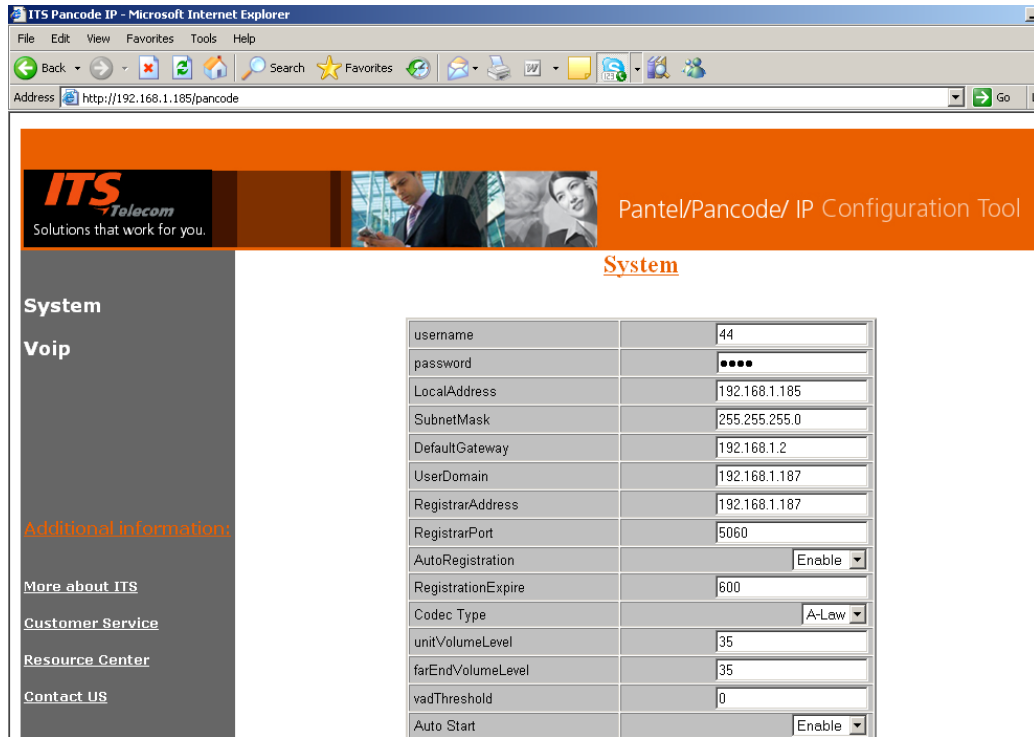

Figure 7-5. Application Interface

The navigation menu contains the following items:

System	Authorization parameters	
	Local network parameters	
	Proxy server parameters	
	Codec Type	
	Volume settings	
	Time mode	
	DHCP support	
	Dialing mode	
	Door opening time	
	Auto Answer mode	
	Video Camera operational mode (optional*)	
	* Video camera operational mode depends on the Door Unit's hardware configuration.	

VoIP Dialing Settings	Speed dialing mode Door Access Codes
	Speed dialing mode destination numbers
	Regular (Normal) Direct dialing mode First digits of Extensions
	Regular (Normal) dialing mode Door Access Codes
	Call Button definitions
	Door opening from extension code
	No answer timeout

The Main Parameters screen contains the following operational buttons:

Submit	Upload modified settings to the Door Unit
Reset to default	Reset Door Unit to the factory default settings
Reboot	Restarts the Door Unit
Upload Config File	Upload previously saved Door Units configuration file. (Note: Saved file renamed to Config. CFG)
Save Config File	Save existing Door Panel configuration as file on local PC drive (the existing configuration file will be saved with extension Config. SAV . For uploading this file need to rename saved file to extension Config. CFG)
Upload Firmware	Activate the updating of the Door Unit's internal firmware. This operation requires original firmware file provided by manufacturer or local dealer.
Upload Kernel	

7.4 System Parameters

The following table details the system parameters. You may require assistance from your LAN administrator.

Parameter Name and Parameters area:

Parameter	Description
Account Name (username)	Contains the unit identification as an SIP proxy server account or VoIP peer-to-peer network. Legal entry: 5 to 20 characters 0-9, A-Z, a-z.
Account Password (password)	Contains the unit authorization on the SIP proxy server. Legal entry: 5 to 20 characters 0-9, A-Z, a-z.
IP Address – Local Address	Identifies the Pantel VoIP/Pancode VoIP device on the TCP/IP network. Legal entry: digits 0-9 only. Example: 192.168.21.10.
Subnet Mask	A mask that determines to which subnet an IP address belongs. Legal entry: digits 0-9 only. Example: 255.255.255.0.
Default Gateway	An identifier for the default gateway on a TCP/IP network for cases, when the Proxy server presents out of local LAN network. Legal entry: 0-9 digits only. Example: 192.14.21.210 .

Parameter	Description
User Domain	In most cases it is the same as the Registrar Address (Proxy server IP address). In special cases it is required to enter Company Domain IP address.
Registrar Address (Proxy IP field)	An identifier for the SIP Proxy server on a TCP/IP network. Legal entry: 0-9 digits only. Example: 192.14.21.210 .
Registrar port (Proxy Port field)	Designed to contain the number of the TCP/IP port used by the unit for communication with SIP Proxy server (IP-PBX). Default port: 5060. Legal entry: Up to 8 digits (0..9).
Auto Registration	
Registration expire (Registration Interval)	Displays the time interval for the unit to register on the Proxy server and to indicate Live status. Legal entry: 0-9999. The setting in this field takes effect only when Enable Auto Registration checkbox is selected.
Codec Type	A Low/MU Low options – enable to select between VoIP codecs supported by the PBX.
Unit Volume level	Microphone Volume – enables to set the microphone volume level as a two-digit parameter. Legal entry: 00 – 63 (00 sets Mute mode).
Far End (Speaker) Volume Level	Speaker Volume – enables to set the speaker volume level as a two-digit parameter. Legal entry: 00 – 63 (00 sets Silent mode).
VAD (Voice Activity Detection) Threshold	When checkbox is selected, activates a field under it. This field contains a virtual value (0-256) that represents a threshold for human voice detection. When voice is detected, the unit will establish a connection with the extension according to the programming in Day and Night numbers (recommended value 20-25).
Auto Start	This parameter is required for manufacturing purposes only.
DSP Firmware version (Voice Operational Mode)	Switching between Full and Half duplex voice transmission modes. Legal entry: 1 – half-duplex mode; 2 – full duplex mode.
Enable DHCP	Enables DHCP service support. IP Door panel will get IP settings automatically in case that DHCP server is present in the LAN.
Product Type	List of available IP Door Panel configuration and functionality. These settings define the device functionality as a panel or Pancode.
Dial Mode	<p>Standard dialing – sets the unit to standard dialing operation mode. In this mode, it is possible to make a direct call to an extension or enter a door-opening access code.</p> <p>Speed-dialing – sets the Pancode VoIP to speed-dialing operation mode. In this mode, it is possible to make a call using a two-digit speed dial code (11 to 35) to internal or external subscribers.</p>

Parameter	Description
Time mode	Day mode and Night mode – enables to select the operational mode of the unit.
Number of errors	Number of Door Access Code error retries, when IP Door Panel will implement calling to Error Number
Panel Session Time Out (Maximum Conversation time)	Call max. duration – displays the time interval for conversation with the target phone's subscriber. You may insert the time parameter in two-digit format in seconds. Legal entry: 10-99 seconds. Unlimited time interval with the 00 settings.
Door open time	Open door interval – enables to set the time interval during which the door lock remains open.
VCR Mode *	Parameter defines the digital camera functionality. * Depends on the firmware and hardware configuration. Contact local dealer or manufacturer for further details.
Low mode (GCI)	General Circuit Interface is the second of two standard synchronous 2B+D ISDN timing interface modes with which this device is compatible. In the GCI mode, the device can communicate in either of the two 64 kbps B-channels. This parameter may be changed by a qualified and authorized person only!
Idl Mode	The Interchip Digital Link interface is one of two standard timing interface modes with which this device is compatible. In the IDL mode, the device can communicate in either of the two 64 kbps channels. This parameter may be changed by a qualified and authorized person only!
Presentation Name	Displays the name that will appear on the digital station display when a call is received from the unit, depending on the VoIP PBX support for this feature.
Auto Answer	
TFTP Server IP address	An identifier for the TFTP server on a TCP/IP network, where configuration files will be stored. The TFTP server can be activated by using the Third Part Company tftp software. For example: Tftpd32 application, which can be found on the following URL: http://www.snapfiles.com/download/dlTftpd32.html)
Config. File name	Previously saved configuration file name, which has to be written here and IP Door Panel will upload it using tftp server settings.
Firmware file name	Internal IP Door Panel Firmware file name. Uploading procedure is the same as Configuration file.
Kernel File name	Internal IP Door Panel Kernel file name. Uploading procedure is the same as Configuration file. This parameter may be changed by a qualified and authorized person only!

Parameter	Description
IP Camera Type *	Type of the digital video camera used in the IP Door panel.
IP Camera Enabling DHCP *	Enables the DHCP mode for the digital video camera.
IP Camera IP Address *	Identifies the Pantel VoIP/Pancode VoIP digital video camera on the TCP/IP network. Legal entry: digits 0-9 only. Example: 192.168.21.10.
IP Camera Subnet mask*	A mask that determines to which subnet an IP address belongs. Legal entry: digits 0-9 only. Example: 255.255.255.0.
IP Camera Gateway *	An identifier for the default gateway on a TCP/IP network.
IP Camera stream Type *	The video stream type supported by the digital video camera.
	* Feature activity depends on the IP Door Panel hardware and software configuration. Contact the local dealer or manufacturer for details.
Software Version	Displays the IP Door panel internal software number.
Hardware Version	Displays the IP Door panel internal hardware edition number.

7.5 VoIP Dialing settings

The VoIP **Dialing Parameters** screen displays the dialing and door opening definitions.

NOTE

Pancode VoIP has two dialing modes: standard and sped-dial. Pantel VoIP has the standard mode only.

The **VoIP Dialing** screen contains the following areas:

Parameter Name and Parameters area:

Parameter	Description
DTMF Transfer type	Defines the mode of providing DTMF tone information in the SIP VoIP network. Possible choice: RFC 2833 or Transparent (In-Band DTMF).
Speed Access Codes 1 to 10	Access Door Opening Codes (speed-dial mode) fields – contain door-opening codes in speed-dial mode. Each field can contain a code of up to 8 digits, which opens the door lock. Legal entries: 0-9 digits only. All codes in this mode must start with 0.

Parameter	Description
Direct Dialing To extension prefix	<p>Prefix for direct dialing field – contains the first digit of a target phone number, to which it is possible to call directly. You can enter up to eight prefixes using a coma separator.</p> <p>Example: Defined prefixes 125 enable to dial directly to numbers beginning with 1, 2 or 5. Digits defined as a direct call prefix may not be used as first digits for access door opening code.</p> <p>The direct dialing feature requires a SIP proxy definition. In case of Peer-To-Peer mode, VoIP gateway IP address can be used as destination and set in the SIP proxy address.</p>
Speed Dialing Numbers (Destination numbers) 11 – 35	<p>Speed dialing subscribers list – contain from 2 to 20 lengths of subscriber's phone numbers. Legal entry: 0..9, *. It is possible to enter 25 codes indexed from 11 to 35.</p> <p>If an IP address is used as a destination, use following format: *XXX*XXX*XXX*XXX, where XXX are digits, the address is prefaced by an asterisk and an asterisk is used as a separator.</p> <p>The access door-opening code in speed-dial mode must start with 0.</p>
Call Button Dialing – Day Mode destination	<p>Day number field – contains the number of the target phone, which will be dialed when a visitor presses the Call button when the device is configured to operate in Day mode. You may insert up to 20 entries, so that a visitor could call different extensions directly. Legal entry: Digits 0-9, ABCD, *.</p>
Call Button Dialing night mode destination	<p>Night number field – contains the number of the target phone, which will be dialed if a visitor will press the Call button when the device is configured to operate in Night mode. You may insert up to 20 entries, so that a visitor could call different extensions directly.</p> <p>Legal entry: digits 0-9, ABCD, *, #.</p>
Call Button Dialing Error mode destination	<p>Error number field – contains the number of the target phone, which will be dialed if a visitor will dial an incorrect access entry code more than three consecutive times. You may insert up to 20 entries.</p> <p>Legal entry: digits 0-9, ABCD, *, #.</p>
Call Button Dial no Answer (Forward No Answer)	<p>Contains the number of the target phone, which will be dialed if a destination number dialed by visitor is not answer during specific time interval. You may insert up to 20 entries.</p> <p>Legal entries: digits 0-9, ABCD, *, #.</p> <p>See also " No Answer Time Out" parameter</p>
Open Door Activation (Door opening code from extension)	<p>– enables to set a code of up to four digits, which could be dialed from any extension during conversation to open the door.</p>

Parameter	Description
Access Codes 1 – 10	Access Door Opening Codes fields – contain door opening codes. Each field can contain a code of up to 8 digits, which opens the door lock. Legal entries: 0-9 digits only. An access door-opening code cannot begin with digits that are used as direct call prefix number.
Peer IP Address	Specify the target Peer device IP address when Peer mode is activated.
Peer Mode	Used mostly for functionality testing purposes. Specify the following type of operation: Visitor dials any free up to 3 digits number and IP Door panel try to establish SIP connection with the target Peer device, where dialed digits used as fourth quarter of the IP address. For example: <ul style="list-style-type: none"> ▪ Peer IP Address is 192.168.21.XXX, where last XXX digits are insignificant. ▪ Visitor dialed 151. ▪ Door panel started to establish connection with the IP address 192.168.21.151
No answer Time Out	Time interval, when a call will be forwarded to the another destination specified in the Call Button Dial no Answer (Forward No Answer) parameter when destination dialed by visitor did not answer.
Off Hook Time Out	This parameter is relevant if the Auto Answer mode is disabled. Specify a maximum time interval in seconds, when the IP Door Panel can be in the No Answer mode during incoming call before rejecting the call.
Inter Digit Time	The maximum allowed keypad dialing inter digit time out interval. Expired time interval time shows to door unit that the destination number or entry code dialing process is finished. Parameter can be set in msec, default value is 3000 msec = 3 seconds

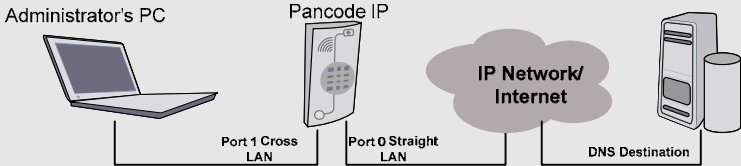
Parameter	Description
DNS IP address *	<p>* - Parameter means for the technical purposes only.</p> <p>This parameter allows to Network administrator to check the IP connectivity by using the "Ping" command and DNS name as argument instead of using the real destination IP address. This procedure is actual if the Administrator PC connected to the Pancode IP switch "Cross" socket.</p> <div data-bbox="628 533 1372 698" data-label="Diagram">  </div> <p>For example: Network Administrator need to check IP connectivity with the internet destination - www.google.com server for to check the Pancode IP network point internet connectivity.</p> <ul style="list-style-type: none"> ▪ Connect PC to "Port 1" Pancode Ip RJ-45 socket ▪ Pancode IP connected to LAN via "Port 0" Straight RJ-45 socket ▪ Insert to the "DNS IP address" field known destination IP address: 66.249.91.104 ▪ Run MS Windows Command prompt window ▪ Enter command: ping www.google.com + enter ▪ Check received results <pre data-bbox="616 1149 1329 1290"> Pinging www.l.google.com [66.249.91.104] with 32 bytes of data: Reply from 66.249.91.104: bytes=32 time=96ms TTL=240 Reply from 66.249.91.104: bytes=32 time=96ms TTL=240 Reply from 66.249.91.104: bytes=32 time=95ms TTL=240 Reply from 66.249.91.104: bytes=32 time=97ms TTL=240 Ping statistics for 66.249.91.104: Packets: Sent = 4, Received = 4, Lost = 0 (0% loss) </pre>

8. Firmware/Software Upgrade

Only a firmware file provided by an authorized ITS Company representative can be used for the IP Door unit software upgrade procedure. The firmware upgrading procedure requires TFTP client software, such as "tftpd32" software.

8.1 Firmware/Software Upgrade Procedure

To upgrade the IP Door unit firmware/software, perform the steps as follows:

- a. Establish a connection session with the destination IP Door device by through the PC Web-browser.
- b. Check the current software version.

TFTP Server IP address	192.168.1.191
Configuration File name	pancode.cfg
Firmware file name	pancode.img
Kernel File name	
Software Version	PIP041107.01.00.28
Hardware Version	PIP0310707.1.0.3

Figure 8-1. Software Upgrade Interface

- c. Enter your PC IP address into **TFTP Server IP address** field.
- d. Enter IP Door unit firmware ***.img** file name into **Firmware file name** field.
- e. Click **Submit** → **Reboot** and re-establish a connection session.
- f. Run the **tftpd32** application, where you must to specify the firmware file storage directory in the **Current Directory** field.
- g. In to the IP Door unit GUI click **Upload Firmware**. **Tftpd32** application screen shows the firmware upgrade status. Connection session with the IP Door unit is interrupted and device is restarted.

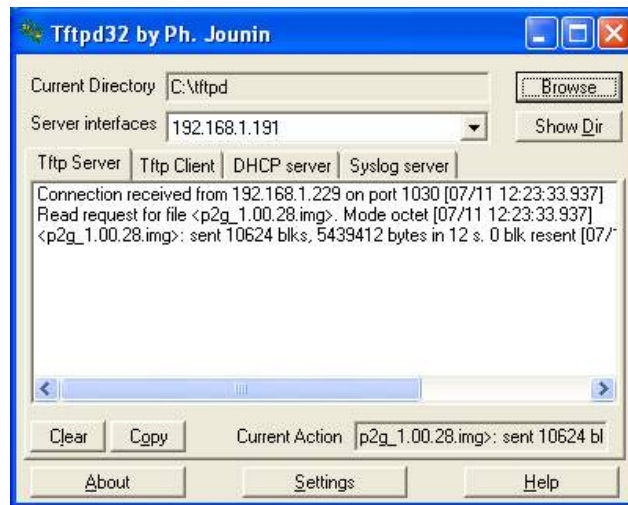

Figure 8-2. Tftpd32 Application Screen

- h. Wait for beep signal, which indicates that device restart process is complete. This may take a few minutes.
- i. Restore the connection session with the IP Door unit.

NOTE

Do not use the Web-browser Refresh option. Instead, type again the unit IP address in the Web-browser URL address field. Format: `http://xxx.xxx.xxx.xxx/pancode`

- j. At the end of the process, the updated firmware version number appears in **Software Version** field.

9. Technical Specification

Power supply	12V AC; 1.5A or Power Over Ethernet IEEE 802.3af compliant
Communication interface	Ethernet for voice; and for programming
DC Leakage	<10 μ A
Imbalance ratio	300-3400Hz > 46dB
Return loss	300-3400Hz > 18dB
Relay switching current	2A max
VoIP protocol supported	SIP; RTP; RTCP
Supported codecs	G.711 PCM (μ /A-Law) at 64 kbps G.726 ADPCM at 16-40 kbps G.727 E-ADPCM at 16-40 kbps G.729 A/B CS-ACELP at 8kbps G.723.1 MP-MLQ at 6.3 kbps G.723 ACELP at 5.3 kbps GSM 6.10 Full Rate at 13.2 kbps GSM Enhanced Full Rate 12.2 kbps AMR at 4.75-2.2 kbps G.729E at 11.8 kbps
Echo canceller	G.168-2002 Compliant with programmable echo tail of up to 128 msec. Full duplex, acoustic EC
Quality Enhancement	Comfort Noise generation (CHG) Packet Loss Concealment (PLC) Adaptive Jitter Buffer(up to 300 msec)
Echo canceller length	Up to 64 msec
IP media features	Automatic Gain Control
In-Band Signaling Detection and Generation	DTMF TIA464B
Dimensions	19.4 X1 0.2 cm
Weight	0.9 kg
Operating temperature	-20°C to +50°C/4°F to 122°F

9.1 Analog Video Camera Technical Specification

Black and White Video Camera

Model number	MK-03261C
TV System	EIA/CCIR
Image Sensor Device	1/3" interline transfer CCD
Image Sensor Area	4.8mm x 3.6mm
Horizontal Frequency	15.625KHz
Vertical Frequency	50Hz
Total Pixels	542(H) x 582(V)
Scanning System	625 lines, 50 fields/sec CCIR
Resolution	420 TVL horizontal
Minimum Illumination	0.5 Lux at F2.0
Electronic Shutter	Auto Electronic Shutter 1/50 to 1/100000 sec. Continual
S/N Ratio	Better than 48 dB
Video Signal Output	1.0Vp-p composite video signal at 75 ohm load
Gamma Correction	0.45
Gain Control	Auto Gain Control (AGC)
Lens & View Angle	5.5 mm F5.5 / 60°

Color Video Camera

Model number	MTV-54KOPI
TV System	PAL/NTSC
Image Sensor	¼-inch CCD Image Sensor
CCD Total Pixels	542(H) x 586(V)
SYNC System	Internal
Minimum Illumination	0.5 Lux F1.2 5600°K
Resolution	380 TVL/470 TVL (Enhanced)
S/N Ratio	52dB (MIN)/60dB(TYP) (AGC OFF)
White Balance	ATW/AWB/FIX (Zero color rolling)
White Balance Range	AWB, ATW (3200---10000°K) /FIX(3299°K)/
Electronic Shutter	1/50-1/120000 sec.
Video Output	1.0Vp-p composite video signal at 75 ohm
Gamma Correction	0.45
Gain Control	AGC
Lens & View Angle	45° > 0.7 mm